

EX-7 series

HITACHI

Reliable solutions

EX2000



HYDRAULIC EXCAVATOR

Model Code: EX2000-7 (Fuel Consumption Optimization)
Engine Gross Power: Cummins: 746 kW (1 014 PS, 1 000 HP)
Operating Weight: Loading Shovel: 192 000 kg (423,288 lb.)
Backhoe: 193 000 kg (425,492 lb.)
Bucket: Loading Shovel: ISO 7546 Heaped 2:1
: 12.0 - 13.5 m³ (15.7 - 17.7 cu. yd.)
Backhoe: ISO 7451:2007
: 12.0 - 14.0 m³ (15.7 - 18.3 cu. yd.)

Model Code: EX2000-7B (Tier 4 Final / EU Stage V)
Engine Gross Power: Cummins: 746 kW (1 014 PS, 1 000 HP)
Operating Weight: Loading Shovel: 194 000 kg (427,697 lb.)
Backhoe: 195 000 kg (429,901 lb.)
Bucket: Loading Shovel: ISO 7546 Heaped 2:1
: 12.0 - 13.5 m³ (15.7 - 17.7 cu. yd.)
Backhoe: ISO 7451:2007
: 12.0 - 14.0 m³ (15.7 - 18.3 cu. yd.)

Model Code: EX2000-7E
Power Output: 610 kW (829 PS, 818 hp)
Operating Weight: Loading Shovel: 190 000 kg (418,878 lb.)
Backhoe: 191 000 kg (421,083 lb.)
Bucket: Loading Shovel: ISO 7546 Heaped 2:1
: 12.0 - 13.5 m³ (15.7 - 17.7 cu. yd.)
Backhoe: ISO 7451:2007
: 12.0 - 14.0 m³ (15.7 - 18.3 cu. yd.)

Introducing the **EX2000-7**

With more than 100 years of experience across group companies, Hitachi is an industry pioneer for mining excavators. The new EX-7 series showcases Hitachi's leading edge with innovative technologies and proven, trusted design.

The all-new EX2000-7 is engineered to reduce fuel consumption and help operations go greener with a range of energy-efficient features while maintaining impressive productivity and reliability.



designed for SUSTAINABILITY

In line with our vision for a zero-emission future in mining, Hitachi's EX-7 excavators are built on the philosophy that machines shouldn't have to sacrifice performance to be sustainable. This philosophy is evident in the EX2000-7 with a range of cutting-edge features – including the new Cummins QST30-C engine – to help operations minimize costs and go greener without sacrificing performance.

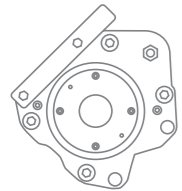

MAIN PUMP ELECTRIC REGULATORS

Each individually controlled hydraulic pump has its own electric regulator, enhancing engine power, lowering fuel consumption, and increasing productivity to lower the total cost of operation.

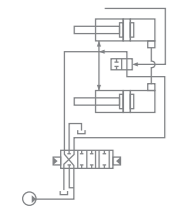

HYDRAULIC REGENERATION CIRCUIT

The flow regeneration valve fitted to the hydraulic system reduces pump demand, ultimately reducing power requirements from the hydraulic system and engine. The result is lower fuel consumption and improved pump life.

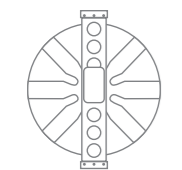

HYDRAULIC OIL COOLER

A larger hydraulic oil cooler with variable speed fan reduces energy demand and creates a more reliable hydraulic system. The oil cooler is kept separate from the radiator to effectively reduce hydraulic oil temperatures, increase hydraulic service life, and improve maintainability.



RADIATOR FAN MOTOR

The radiator fan is now driven by a hydraulic system, replacing the previous mechanical drive system. The fan automatically adjusts to meet engine requirements, creating an optimized cooling system with less horsepower demand and less operational noise.



ENGINE-PUMP (E-P) CONTROL

Hitachi's computer-aided Engine-Pump (E-P) Control achieves optimum productivity from the engine and hydraulic pumps. The innovative system senses load demand and controls engine and pump output to match the work being performed, maximizing operating efficiency and lowering fuel costs for large workloads.



CONTROL VALVE WITH INDIVIDUAL PILOT PRESSURE CONTROL

The EX2000-7's hydraulic system conserves energy as each individual control valve is closely adjusted to direct the exact required amount of pressure to each cylinder and swing motor from the pumps.



DIESEL DRIVERS

EX2000-7 (FCO)

The EX2000-7 model, equipped with Cummins FCO* (Non-Certified) engine that optimizes fuel consumption.

CUMMINS

Cummins QST30-C, 746 kW (1 014 PS, 1 000 HP)

*FCO: Fuel Consumption Optimization

EX2000-7B (TIER 4 FINAL/EU STAGE V)

The EX2000-7B model, equipped with US EPA Tier 4 Final / EU Stage V emission regulations-compliant Cummins engine.

CUMMINS

Cummins QST30-C with SCR (Selective Catalytic Reduction) after-treatment system, 746 kW (1 014 PS, 1 000 HP)

ELECTRIC DRIVERS

EX2000-7E

The EX2000-7E electric excavator utilizes the Hitachi AC electric motor without the diesel exhaust emissions.

HITACHI ELECTRIC MOTOR

Hitachi TFOA-KK, 610 kW (1 169 PS, 1 153 HP)
 · 50 Hz, 6000 V, 6600 V**
 · 60 Hz, 6600 V, 6900 V**

**Please contact hitachi for other specification request



designed for
PRODUCTIVITY

The EX-7 is engineered for productivity. The EX2000-7 features a power-focused design, including a larger bucket, to deliver consistently impressive output for mining operations.

FRONT ATTACHMENT

With a front attachment design that prioritizes performance, the EX2000-7 can achieve superior productivity under different digging profiles. The boom and arm are strategically welded, utilizing a full-box section design to evenly distribute stress and provide ease of maintenance.

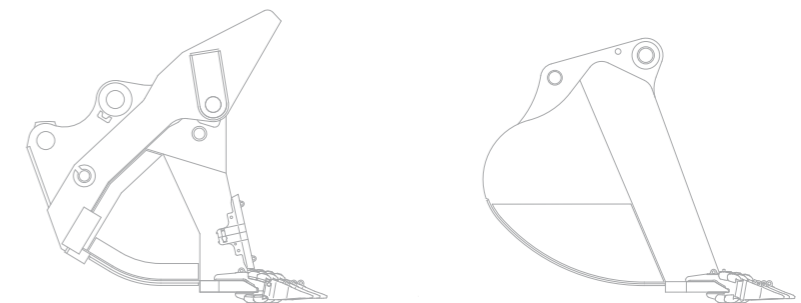

LOADING SHOVEL

The Loading Shovel attachment is equipped with an auto-leveling crowd mechanism that controls the bucket at a constant angle. The EX2000-7 now has a larger 12.0 m³ (15.7 cu. yd.) bucket, designed to increase loading capability with a tilt angle that enhances operational efficiency.

LOADING SHOVEL EXCAVATING FORCE

Arm crowding force on ground
 700 kN (71 320 kgf, 157,234 lbf.)

Bucket digging force
 737 kN (75 120 kgf, 165,611 lbf.)

BACKHOE

The Backhoe attachment is designed using computer-aided box frame analysis to determine the optimal structure for integrity and longevity. Complete with a floating pin and bush, the bucket has been designed to match the geometry of the attachment to maximize productivity.

BACKHOE EXCAVATING FORCE

Arm crowding force
 628 kN (64 700 kgf, 142,639 lbf.)

Bucket digging force
 701 kN (71 500 kgf, 157,631 lbf.)

designed for **SAFETY**

Hitachi's ultimate priority is always safety. That's why the EX2000-7 has a range of safety features, like spacious walkways, improved handrails and a dual isolator switch as standard, to make it one of the safest excavators in its class on the market.



DUAL ISOLATOR SWITCH

The conveniently located dual isolator switch offers the option to deactivate the engine and battery individually.

When inspections and maintenance are required, the battery isolator provides the benefit of isolating both the positive and negative terminals of the battery for a safe working environment. The engine isolator deactivates the engine starter motor while allowing battery power to the electric system for troubleshooting, to enhance safety and maintainability.

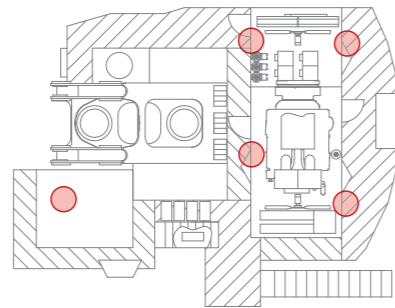

ENGINE STOP SWITCHES

Engine stop switches have been placed in easily accessible areas: two in the engine room, two in the pump room, and one emergency stop switch in the cab.



ON-BOARD INCLINOMETER

The on-board inclinometer assists the operator to work within the safe limits of the machine, with two predetermined safety limits providing extra assurance. If the first safety limit is exceeded, the operator receives a visual alert prompting them to take corrective action. The alert escalates to an audible alarm if the second safety limit is breached.

PERIMETER MONITORING CAMERAS (OPTIONAL)

Optional perimeter monitoring cameras offer better visibility of a surrounding area, reducing blind spots for the operator. Two cameras are located at both the front and rear of the excavator and are linked to monitors inside the cab.

ACCESS AND WALKWAYS

Anti-slip walkways and specially designed handrails reduce the risk of tripping when maneuvering around the machine and provide ease of access for operators and maintenance personnel.

Hydraulically operated, electrically controlled folding stairs allow for easy and safe access to the machine.

EMERGENCY ESCAPE CHUTE

An escape chute can be added to the side of the cab for use in an emergency. The chute allows evacuees to descend vertically down from the machine, providing a safe and fast route of escape when all other means of exit are blocked.

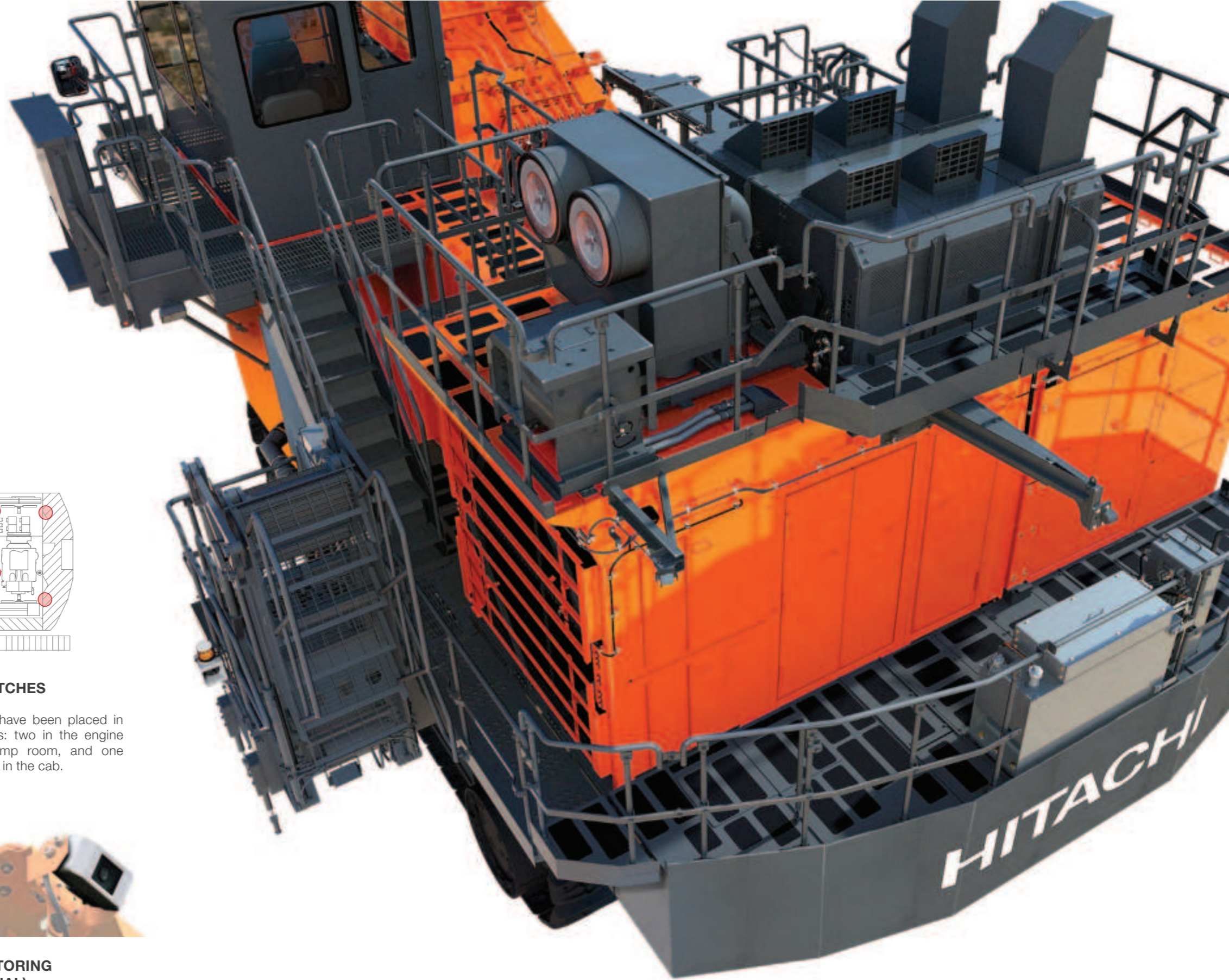

designed for

OPERATOR COMFORT

Hitachi's EX-7 series provides operators with a superior level of comfort. Electronic joysticks, an intelligent Multi-Functional Display, advanced air suspension seating, and improved climate control make operation of the EX2000-7 effortless and productive.

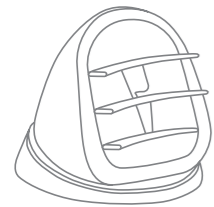

CLIMATE CONTROLLED AIR CONDITIONING

The pressurized cab's climate controlled air conditioning helps to overcome environmental extremes. Optimized filtering of interior and exterior air combined with the new flexi-vent system provides a personalized and balanced environment that meets operator demands.

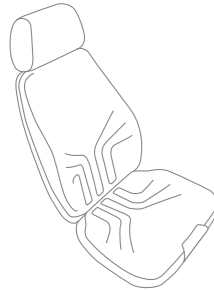

OPERATOR SEAT

Specifically designed for use in the mining industry, the automatic weight-adjusting air suspension seat calculates optimal cushioning to match the operator's weight, enhancing comfort and minimizing vibration.

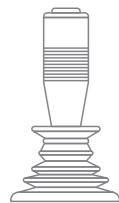

ELECTRONIC JOYSTICKS

Integrated electronic joysticks connected to the machine's microprocessor enable precise and almost effortless operation, minimizing operator fatigue and improving operational performance.

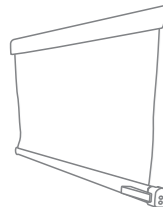

ROLL SCREENS

Retractable front and side roll screens protect the operator from UV glare and reduce heat buildup in the cab, improving the efficiency of the climate controlled air conditioner for a superior operating environment.

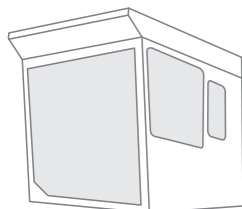

OPERATOR CABIN

The use of laminated tinted windows reduce heat and glare in the cab, while sound-suppression further enhances ergonomics and comfort for the operator.

OPG top guard level II compliant with ISO 10262:1998 provides secure protection from falling objects, ensuring operator safety.

MULTI-FUNCTIONAL DISPLAY

Fitted with an LED back-light to improve clarity and reduce glare, the multi-functional display provides key machine information and performance indicators through use of an integrated dial switch interface.



designed for
**EASE OF
 MAINTENANCE**

Hitachi's EX-7 series is designed to safeguard and simplify maintenance with its intuitive design. A modular arrangement with spacious passageways and work platforms makes the EX2000-7 easy and safe to maintain.



MAINTENANCE ACCESS
 Wide center walkways and open service areas offer ease of access for daily maintenance tasks and make engine, hydraulic, and electrical component inspections easy.

AUTO-LUBRICATION SYSTEM

A new auto-lubrication system comes with 200 L (52 gal.) large capacity grease tank, new grease pump, in-line grease filter with breather, grease level indicator in cab and provision for fitment of a second grease pump in the lubrication tank. These features provide a more reliable system with less downtime.

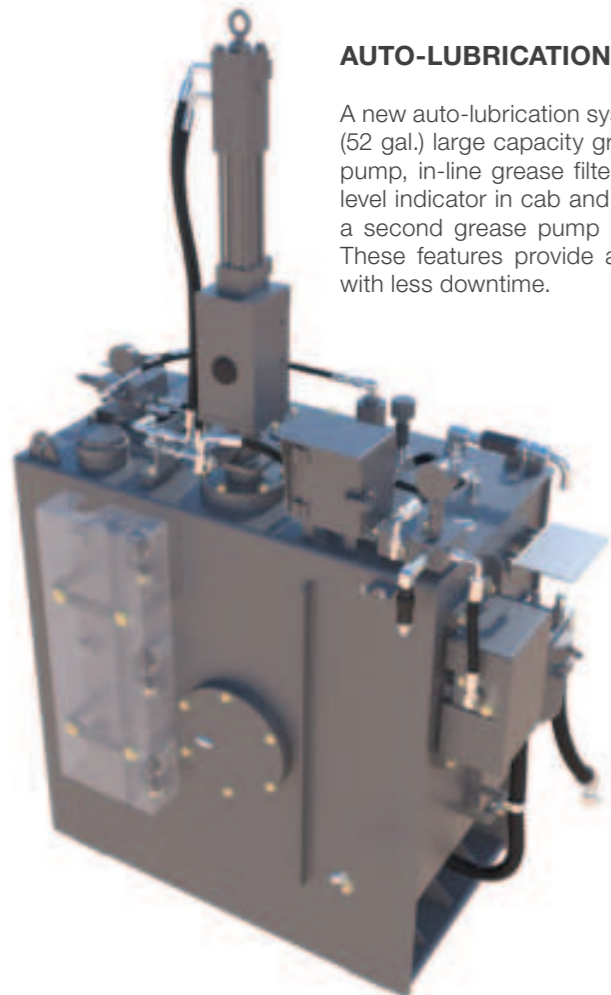

CONTAMINATION SENSORS

Contamination sensors are located on main hydraulic pumps, travel motors and swing motors to detect any contaminants that may cause damage to the hydraulic system. Sensors alert the operator of potential contaminants and record the fault code in the Data Logging Unit (DLU), with the capability to remotely advise maintenance personnel.



CENTRALIZED LUBRICATION SYSTEM

The centralized fast-filling system provides easy access from the ground to refill and evacuate lubricants, water, grease and fuel. The fast-filling system can be fitted with an optional quick coupler.

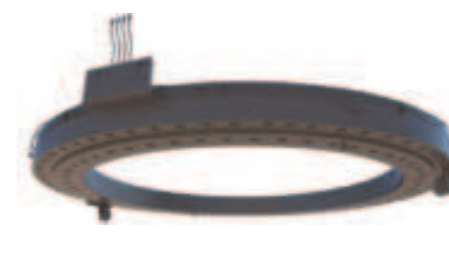

LUBRICATION PIPING COVER

A swing circle cover has been added to the outside of the swing bearing, protecting the lubrication piping from debris damage.



GREASE-LESS CENTER JOINT

The new center joint employs the machine's hydraulic oil to self-lubricate, reducing the need for daily maintenance.



designed for
DURABILITY

Hitachi's EX-7 excavators are built to last under the toughest of conditions. Advanced computer modelling, specialized forgings, and specially designed track shoes are just some of the features that maximize longevity and contribute to a low cost per hour on the EX2000-7.



STRONG MAINFRAME

The EX2000-7 features a stronger, more durable mainframe than previous models. Stress is now more evenly dispersed across the improved frame shape, increasing machine durability and reducing downtime.

REINFORCED ARM & BOOM

The connection between the EX2000-7 arm and boom has been upgraded from one connecting pin to two connecting pins, increasing front attachment durability.



TRACK LINK

Hitachi's classic track link design has been applied to mitigate premature wear of the drive-lugs. Each shoe is induction hardened using Hitachi's proven methods to deliver a superior and more durable solution.



UPPER ROLLERS

The EX2000-7 undercarriage has three double-sided, pedestal-designed upper rollers on each side of the track frame. These rollers maintain track shoe clearance and provide protection from debris buildup, reducing shoe and roller wear for a more reliable undercarriage system.



CENTER FRAME UNDERGUARD (OPTIONAL)

A newly designed heavy duty guard protects hoses and accumulators located in the track center frame from rocks and debris ingress, providing extra protection and reliability.

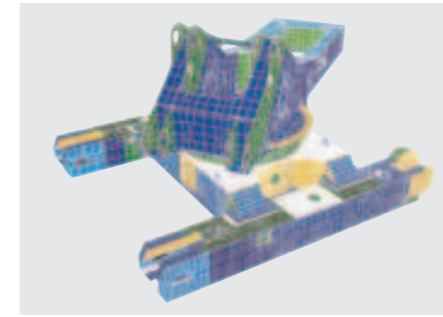

RIGID BOX DESIGN

Computer assisted analysis has been used to determine the most effective design for frame longevity, ensuring the EX2000-7 withstands the demands of any mining operation.



CENTER TRACK FRAME

Hitachi's exclusive center track frame delivers optimal stress dispersion through the use of specially designed forged steel parts to reduce the chance of failure in critical high-stress areas. This guarantees a stronger frame with improved durability.



OIL-FILLED ROLLERS & IDLERS

The oil-filled idlers and upper and lower rollers eliminate the need for daily lubrication, helping reduce maintenance costs.

designed for
RELIABILITY

Evolving from years of operational experience and engineering excellence, the Hitachi EX-7 series of excavators continue to drive innovation in the mining industry. The EX2000-7 combines cutting-edge technologies with proven designs for superior operation that can be counted on.



ELECTRONIC CYLINDER STROKE CONTROL

The new on-board electronic controller receives signals from angle sensors fitted to the main frame, boom and arm to control the pump flow rate and cylinder speed. Shock at stroke end of the cylinder cycle is reduced, improving operator comfort and lowering impact on cylinders and structures for more reliable operation.

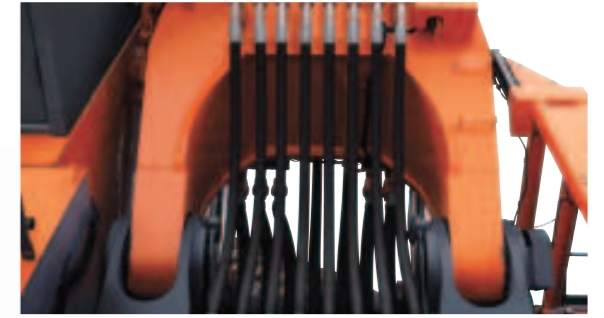

FRONT ATTACHMENT HOSES

Hitachi's hose design has been tested on a high cyclic fatigue rate to maximize longevity and improve safety. Front attachment hoses have been rearranged from the traditional arch style to an underslung configuration, removing the need for clamping, reducing chafing and increasing reliability.



OPERATING LIGHTS

Strategically placed long-life LED working lights provide assured reliability for night operations.



CAB RISER PRESSURIZER

The cab riser now features a pressurizer system to reduce dust infiltration, extending service life of the electronic components and devices within.

designed for
INTELLIGENCE

Hitachi is dedicated to the advancement of mining through digital innovation and connectivity. The EX2000-7 features extensive onboard sensors, diagnostic tools, and advanced software to deliver exceptional insights, empowering operations to achieve more in real time.

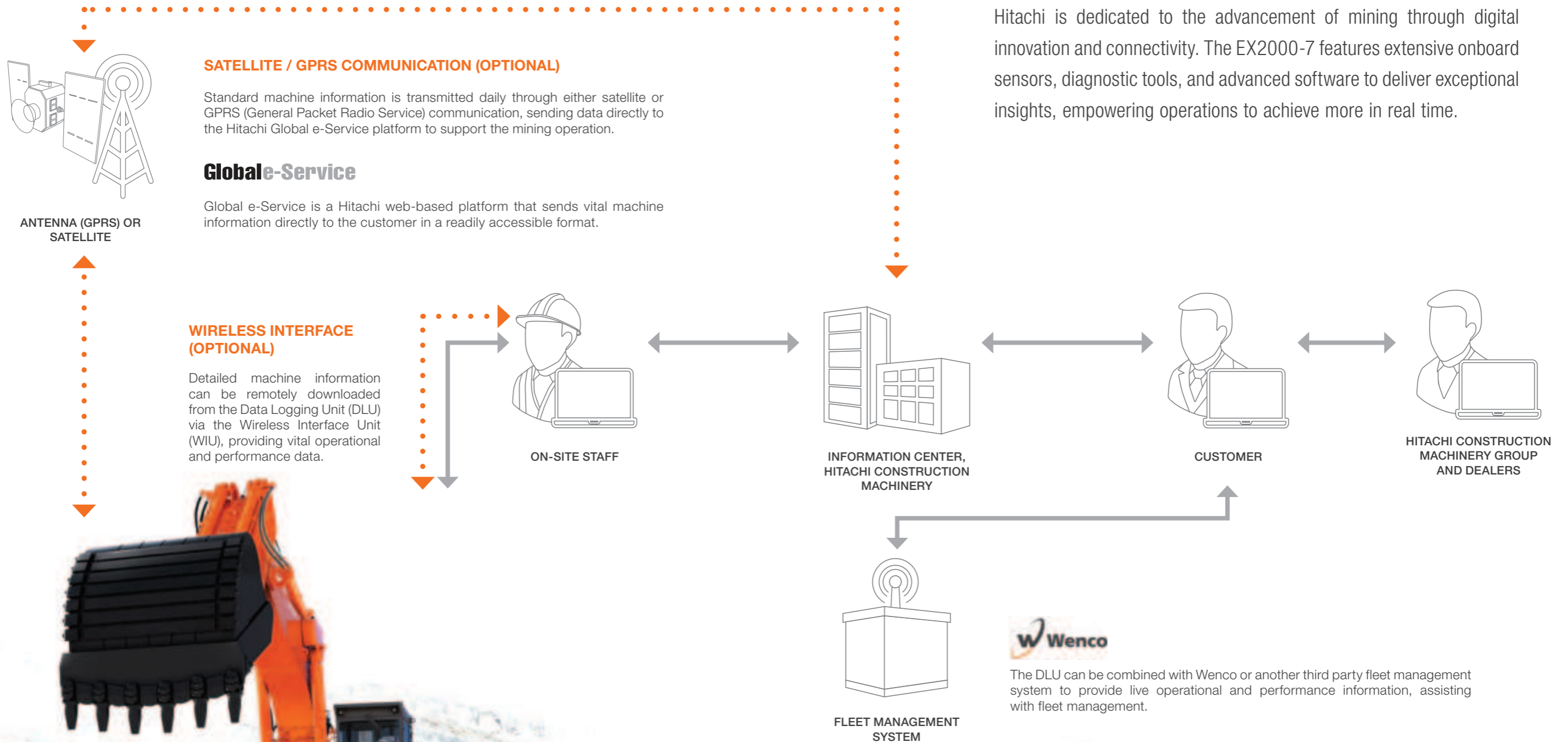

SATELLITE / GPRS COMMUNICATION (OPTIONAL)

Standard machine information is transmitted daily through either satellite or GPRS (General Packet Radio Service) communication, sending data directly to the Hitachi Global e-Service platform to support the mining operation.

Globe-Service

Global e-Service is a Hitachi web-based platform that sends vital machine information directly to the customer in a readily accessible format.

WIRELESS INTERFACE (OPTIONAL)

Detailed machine information can be remotely downloaded from the Data Logging Unit (DLU) via the Wireless Interface Unit (WIU), providing vital operational and performance data.

Aerial Angle (OPTIONAL)

Aerial Angle provides the operator with a real-time continuous birds-eye view around their excavator. Cameras strategically mounted on the machine generate a single aerial view of the EX2000-7 surroundings. Multiple screen display options can be selected on the cab's 12-inch Aerial Angle monitor for ease of operation.

SPECIFICATIONS

WORKING RANGES

Loading Shovel

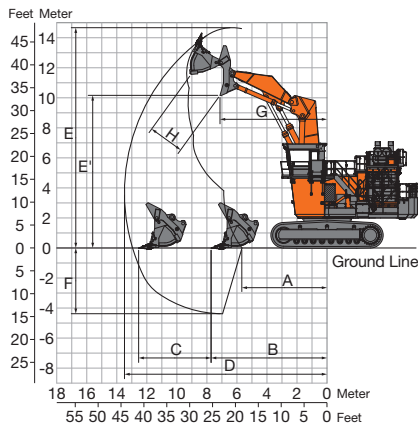

Bucket Capacity ISO 7456 (Heaped 2:1)	12.0 m ³ (15.7 cu. yd.)
A: Minimum Digging Distance	5 660 mm (18 ft. 7 in.)
B: Minimum Level Crowding Distance	7 720 mm (25 ft. 4 in.)
C: Level Crowding Distance	4 830 mm (15 ft. 10 in.)
D: Maximum Digging Reach	13 490 mm (44 ft. 3 in.)
E: Maximum Cutting Height	14 670 mm (48 ft. 2 in.)
E': Maximum Dumping Height	10 160 mm (33 ft. 4 in.)
F: Maximum Digging Depth	4 380 mm (14 ft. 4 in.)
G: Working Radius at Maximum Dumping Height	7 130 mm (23 ft. 5 in.)
H: Maximum Bucket Opening Width	2 380 mm (7 ft. 10 in.)
Arm crowding force on ground	700 kN (71 320 kgf, 157,234 lbf.)
Bucket digging force	737 kN (75 120 kgf, 165,611 lbf.)

Backhoe

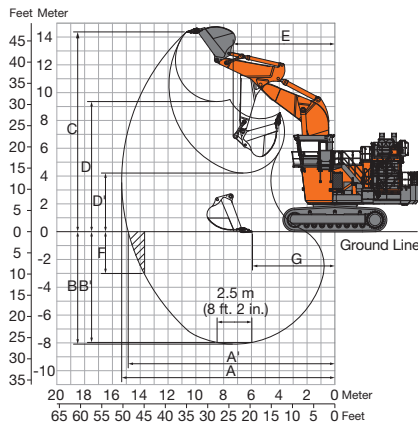

BE-boom length	8.3 m (27 ft. 3 in.)
BE-arm length	3.6 m (11 ft. 10 in.)
Bucket capacity (ISO 7451: 2007)	12.0 m ³ (15.7 cu. yd.)
A: Maximum Digging Reach	15 340 mm (50 ft. 4 in.)
A': Maximum Digging Reach (on ground)	14 870 mm (48 ft. 9 in.)
B: Maximum Digging Depth	8 090 mm (26 ft. 7 in.)
C: Maximum Digging Depth	7 970 mm (26 ft. 2 in.)
D: Maximum Digging Depth (2.5 m (8 ft. 2 in.) level)	7 970 mm (26 ft. 2 in.)
D': Maximum Digging Depth	7 970 mm (26 ft. 2 in.)
E: Maximum Cutting Height	14 370 mm (47 ft. 2 in.)
E': Maximum Dumping Height	9 360 mm (30 ft. 9 in.)
F: Minimum Swing Radius	4 220 mm (13 ft. 10 in.)
G: Maximum Vertical Wall	7 310 mm (24 ft.)
H: Minimum Level Crowding Distance	3 010 mm (9 ft. 11 in.)
Bucket Digging Force (ISO 6015: 2006)	701 kN (71 500 kgf, 157,631 lbf.)
Arm Crowd Force (ISO 6015: 2006)	628 kN (64 700 kgf, 142,639 lbf.)

DIMENSIONS

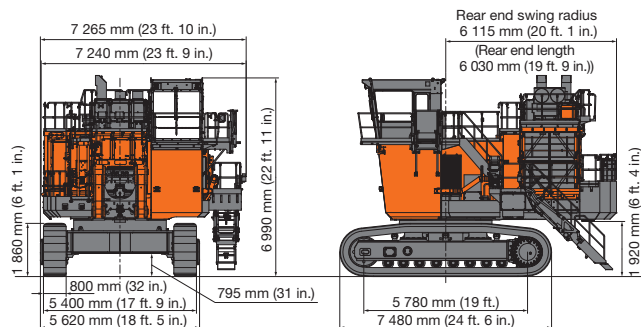

UPPER STRUCTURE

Swing speed	4.7 min ⁻¹ (rpm)
Fuel tank capacity	3 690 L (975 gal.)
DEF tank capacity	
(T4F / EU Stage V only)	241 L (64 gal.)

HYDRAULIC SYSTEM

Main Pumps	6 variable-displacement, axial piston pumps for front attachment, travel and swing
Pressure setting	29.4 MPa (300 kgf/cm ² , 4,264 psi)
Max. oil flow	6 x 335 L/min. (6 x 88 gal./min.)

UNDERCARRIAGE

Travel speeds	High: 0-2.8 km/h (0-1.7 mph) Low: 0-2.1 km/h (0-1.3 mph)
---------------	---

WEIGHTS AND GROUND PRESSURE

Loading Shovel

Equipped with 12.0 m³ (15.7 cu. yd.) ISO 7546 Heaped 2 : 1 bottom dump bucket

Shoe width	Weight	Ground pressure
800 mm (32 in.)	194 000 kg (427,697 lb.)	187 kPa (1.90 kgf/cm ² , 27.1 psi)

Backhoe

Equipped with 12.0 m³ (15.7 cu. yd.) ISO 7451: 2007 bucket

Shoe width	Weight	Ground pressure
800 mm (32 in.)	195 000 kg (429,901 lb.)	188 kPa (1.91 kgf/cm ² , 27.3 psi)

Cummins T4F configuration

ATTACHMENTS

Loading Shovel:

ISO 7546 Heaped 2 : 1:

12.0 m³ (15.7 cu. yd.): Material density 1 800 kg/m³ (3,034 lb./cu. yd.) or less
13.5 m³ (17.7 cu.yd.): Material density 1 600 kg/m³ (2,697 lb./cu.yd.) or less

Backhoe:

ISO 7451: 2007:

12.0 m³ (15.7 cu. yd.): Material density 1 800 kg/m³ (3,034 lb./cu. yd.) or less
14.0 m³ (18.3 cu.yd.): Material density 1 600 kg/m³ (2,697 lb./cu.yd.) or less

ENGINE

Model	Cummins QST30-C (FCO, T4F/EU Stage V)
Rated power	
ISO 14396: 2002, gross	746 kW (1 014 PS, 1 000 HP) at 1 800 min ⁻¹ (rpm)
Piston displacement	30.5 L (1,861 cu.in.)

ENVIRONMENT

Auto control air conditioner contains fluorinated greenhouse gases.

Refrigerant type	HFC-134a
GWP	1430
Amount	2.80 kg (6.17 lb.)
CO ₂ e	4.00 tonnes (4.41 tons)

PASS MATCH

Best match: 4-6 passes

Potential match: 3-8 passes

Model		60t class truck	100t class truck	EH3500AC-3	EH4000AC-3
EX1200-7	BH 7.0 m ³ (9.2 cu. yd.)	5			
	LD 6.5 m ³ (8.5 cu. yd.)	6			
EX2000-7	BH 12.0 m ³ (15.7 cu. yd.)	3	5		
	LD 12.0 m ³ (15.7 cu. yd.)	3	5		
EX2600-7	BH 17.0 m ³ (22.2 cu. yd.)		3	6	8
	LD 15.0 m ³ (19.6 cu. yd.)		4	8	

Before using a machine with a satellite communication system or telecommunication system, please make sure that the satellite communication system or telecommunication system complies with local regulations, safety standards and legal requirements. If not so, please make modifications accordingly.

These specifications are subject to change without notice. Illustrations and photos show the standard models, and may or may not include optional equipment, accessories, and all standard equipment with some differences in color and features. Before use, read and understand the Operator's Manual for proper operation.