

Dynapac DRP15D

Plate compactors



Technical data



Masses

Basic mass	147 kg
Operating mass	150 kg



Traction

Max. gradeability	30 %
Max. working speed	25 m/min



Compaction

Frequency	85 Hz
Centrifugal force	25 kN
Amplitude	1.55 mm
Water tank volume	12 l



Engine

Manufacturer/Model	Hatz 1B20
Emissions according to	Stage V /non EPA
Type	Air cooled, diesel
Number of cylinders	1
Fuel consumption /h, avg.	0.7 l
Fuel tank capacity	3 l
Power	3.1 kW @ 3000 rpm



Drive system

Drive system	Mechanical
--------------	------------

Find us locally at www.dynapac.com

We reserve the right to change specifications without notice. Photos and illustrations do not always show standard versions of machines. The above information is a general description only, all informations are supplied without liability.

Dynapac DRP15D

Plate compactors



Technical data

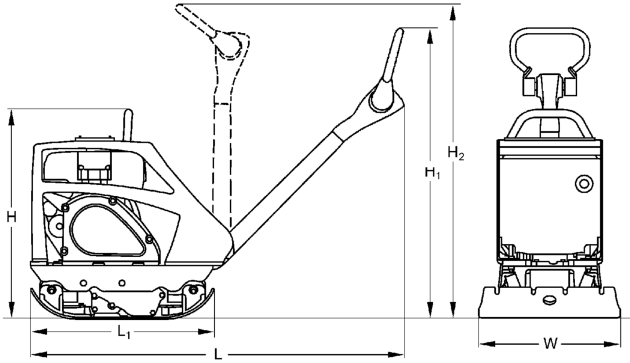

Dimensions	
H. Height	740 mm
H1. Height	930 mm
H2. Height	1080 mm
L. Length	1460 mm
L1. Length	650 mm
W. Basic plate width	400 mm



Standard equipment

- Control handle with vibration isolation
- Height adjustable control lever
- Control lever lock in transport and working position
- Reverse drive protection
- Highly wear resistant base plate
- All around protection hood
- All around protection for V-belt
- One point lift
- Automatic decompression
- Recoil starter



Optional equipment

- Block paving mat
- Puncture proof transport wheels (+4kg)
- Water sprinkler system 12l (+13kg)
- Service Kit

Find us locally at www.dynapac.com

We reserve the right to change specifications without notice. Photos and illustrations do not always show standard versions of machines.
The above information is a general description only, all informations are supplied without liability.